

# STA-RITE®

## IntelliPro™ 4x160 and 4x100 Four Speed Variable Centrifugal Pump with Integral Trap

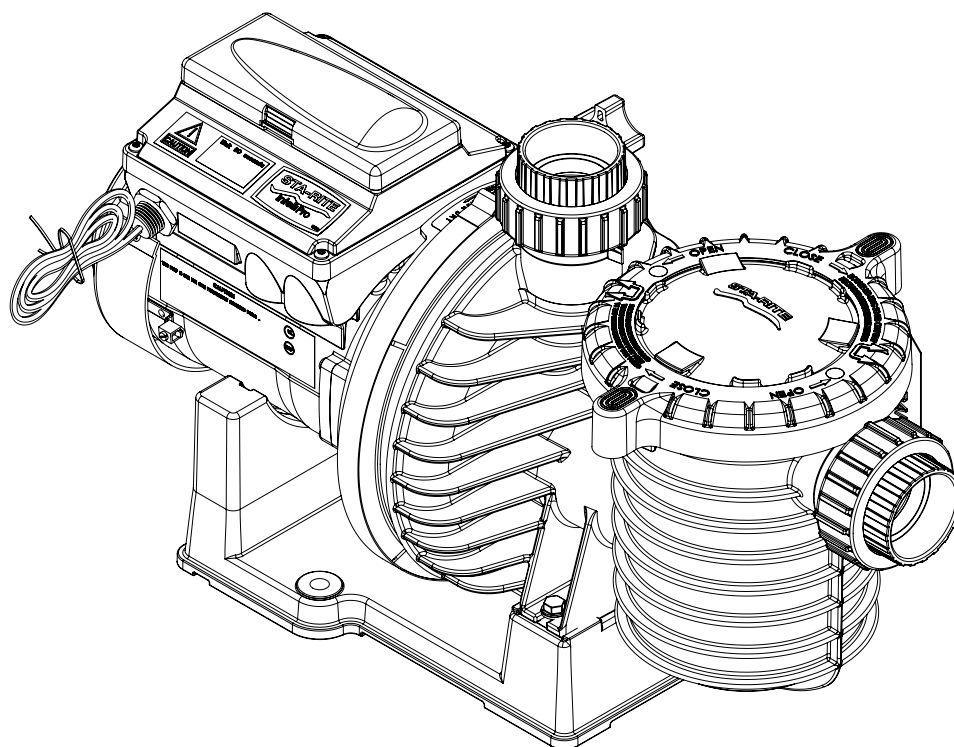

IMPORTANT SAFETY INSTRUCTIONS  
READ AND FOLLOW ALL INSTRUCTIONS  
SAVE THESE INSTRUCTIONS

 **Pentair Water**  
Pool and Spa®

## **Technical Support**

**Sanford, North Carolina** (8 A.M. to 5 P.M.)

Phone: (800) 831-7133

**Moorpark, California** (8 A.M. to 5 P.M.)

Phone: (800) 831-7133

**Fax:** (800) 284-4151

**Web sites:** visit [www.pentairpool.com](http://www.pentairpool.com) and [staritepool.com](http://staritepool.com)

**© 2006 Pentair Water Pool and Spa, Inc. All rights reserved**

**This document is subject to change without notice**

1620 Hawkins Ave., Sanford, NC 27330 • (919) 566-8000  
10951 West Los Angeles Ave., Moorpark, CA 93021 • (805) 553-5000

Sta-Rite, IntelliTouch, EasyTouch, IntelliPro and the Pentair Water Pool and Spa logo are trademarks of Pentair Water Pool and Spa, Inc. Other trademarks and trade names may be used in this document to refer to either the entities claiming the marks and names or their products. Pentair Water Pool and Spa, Inc. disclaims proprietary interest in marks and names of others.

# Contents

<b>Important Safety Precautions .....</b>	<b>iii</b>
<b>Section 1: Overview .....</b>	<b>1</b>
IntelliPro Variable Speed Pump .....	1
IntelliPro models .....	1
External Control .....	1
Features .....	2
IntelliPro Motor Assembly .....	2
Drive assembly and electronics enclosure .....	2
Motor fan cover .....	2
Motor assembly .....	2
Operator Control Panel .....	2
Communication Port for communication to IntelliTouch, or IntelliComm via the two-wire RS-485 cable .....	2
IntelliPro Drive Assembly and Control Panel .....	3
IntelliPro Motor Features .....	3
IntelliPro Operator Control Panel .....	4
Controls and LEDs .....	4
<b>Section 2: Installation .....</b>	<b>5</b>
Before installation .....	5
Teflon Taping Instructions .....	5
Piping .....	6
Fittings .....	6
Wiring the IntelliPro .....	7
External Control with IntelliComm Communication Center .....	8
Connecting IntelliPro 4 to an EasyTouch System .....	9
Connecting IntelliPro 4 to an IntelliTouch System .....	12
<b>Section 3: Operation .....</b>	<b>15</b>
Setting the pump preset speed .....	15
Adjusting the pump speed .....	16
Starting the pump .....	16
Stopping the pump .....	16
Setting the pump communication address .....	16
Resetting the pump to factory defaults .....	17
Priming the pump for the first time or after service .....	18
Priming the Pump .....	19
Storage/Winterizing: .....	20
Draining Pump .....	20
Startup For Winterized Equipment .....	21
Pump Service .....	21

## Contents (Continued)

<b>Section 4: User Maintenance .....</b>	<b>23</b>
Pump Strainer Basket .....	23
Pump Strainer Basket Service .....	23
Motor Service .....	24
Winterizing .....	25
Priming the pump after service .....	25
Pump Disassembly .....	27
 <b>Section 5: Removal and Replacement .....</b>	 <b>27</b>
Drive Assembly Removal and Installation .....	27
Pump Disassembly/Removing Old Seal .....	29
Pump Reassembly/Installing New Seal .....	30
Illustrated Parts List .....	31
IntelliPro Flow and Power vs Flow Pump Curve .....	32
IntelliPro Electrical Specifications .....	32
IntelliPro Pump Dimensions .....	32
 <b>Section 6: Troubleshooting .....</b>	 <b>33</b>
Warning and Alarm conditions .....	33
Alarm and warning LED sequence .....	33
General IntelliPro Troubleshooting Problems .....	34



## IMPORTANT SAFETY PRECAUTIONS



### Important Notice:

**Attention Installer:** This manual contains important information about the installation, operation and safe use of this product. This information should be given to the owner and/or operator of this equipment.



**WARNING** — Before installing this product, read and follow all warning notices and instructions which are included. Failure to follow safety warnings and instructions can result in severe injury, death, or property damage. Call (800) 831-7133 for additional free copies of these instructions.



### WARNING — Entrapment Avoidance Notice:



The suction outlet connected to a swimming pool or spa pump can pull a high vacuum if it is blocked. Therefore, if only one suction outlet smaller than 18" x 23" is used, anyone blocking the suction outlet with their body can be trapped and held against the suction outlet. Disembowelment or drowning can result. Therefore, if small suction outlets are used with this pump, to prevent this entrapment and possible death, install at least two suction outlets in the body of water. Separate these suction outlets as described in the International Residential Code (IRC), the International Business Code (IBC), the Consumer Products Safety Council (CPSC) Guidelines for Entrapment Hazards: Making Pools and Spas Safer or ANSI/IAF-7 Standard for Suction Entrapment Avoidance in Swimming Pools, Wading Pools, Spas, Hot Tubs and Catch Basins. If suction outlets are not used, additional entrapment avoidance measures as described in the CPSC Guidelines or ANSI/IAF-7 should be employed.

The covers used on suction outlets should be approved and listed as conforming to the currently published edition of ANSI/ASME A112.19.8 Standard covering Suction Fittings for Use in Swimming Pools, Wading Pools, Spas and Hot Tubs. These covers should be inspected regularly and replaced if cracked, broken or older than the design lifetime indicated on them by the manufacturer. The maximum possible flow rate of this pump should be less than or equal to the maximum approved flow rate indicated on the suction outlet cover by the manufacturer. **THE USE OF UNAPPROVED COVERS OR ALLOWING USE OF THE POOL OR SPA WHEN COVERS ARE CRACKED OR BROKEN CAN RESULT IN HAIR ENTANGLEMENT WHICH CAN RESULT IN DEATH.**



### WARNING — Risk of electrical shock or electrocution.



This pool pump must be installed by a licensed or certified electrician or a qualified pool serviceman in accordance with the National Electrical Code and all applicable local codes and ordinances. Improper installation will create an electrical hazard which could result in death or serious injury to pool users, installers, or others due to electrical shock, and may also cause damage to property.

**Always disconnect power to the pool pump at the circuit breaker before servicing the pump.** Failure to do so could result in death or serious injury to serviceman, pool users or others due to electric shock.

## IMPORTANT SAFETY PRECAUTIONS (continued)



**WARNING** — Water temperature in excess of 100° Fahrenheit may be hazardous to your health. Prolonged immersion in hot water may induce hyperthermia. Hyperthermia occurs when the internal temperature of the body reaches a level several degrees above normal body temperature of 98.6° F. (37° C.). The symptoms of hyperthermia include: drowsiness, lethargy, dizziness, fainting, and an increase in the internal temperature of the body.



The effects of hyperthermia include: 1) Unawareness of impending danger. 2) Failure to perceive heat. 3) Failure to recognize the need to leave the spa. 4) Physical inability to exit the spa. 5) Fetal damage in pregnant women. 6) Unconsciousness resulting in danger of drowning.



**WARNING** — **The use of alcohol, drugs, or medication can greatly increase the risk of fatal hyperthermia in hot tubs and spas.**



**WARNING** — To reduce the risk of injury, do not permit children to use this product unless they are closely supervised at all times.



**WARNING** — For units intended for use in other than single-family dwellings, a clearly labeled emergency switch shall be provided as part of the installation. The switch shall be readily accessible to the occupants and shall be installed at least 5 feet (1.52 m) away, adjacent to, and within sight of, the unit.



**WARNING** — When setting up pool water turnovers or flow rates the operator must consider local codes governing turnover as well as disinfectant feed ratios.



**WARNING** — Before servicing the system, switch the main power OFF and remove the communication cable from the pump.



**CAUTION** — Install the pump a minimum of five (5) feet from the inside wall of the pool and spa. Canadian installations require a minimum of three (3) meters from pool water.



**CAUTION** — A No. 8 AWG (No. 6 AWG in Canada) or larger conductor must be wired to the motor bonding lug.



**CAUTION** — This pump is for use with permanently installed pools and may also be used with hot tubs and spas if so marked. Do not use with storable pools. A permanently installed pool is constructed in or on the ground or in a building such that it cannot be readily disassembled for storage. A storable pool is constructed so that it may be readily disassembled for storage and reassembled to its original integrity and has a maximum dimension of 18 feet (5.49m) and a maximum wall height of 42 inches (1.07m).



**CAUTION** — For hot tubs and spa pumps, do not install within an outer enclosure or beneath the skirt of a hot tub or spa unless so marked.



**CAUTION** — IntelliPro is capable of generating systems pressures up to 50 psi. Installers must ensure that all system components are rated to withstand at least 50 psi. Over pressurizing the system can result in catastrophic component failure or property damage.

### General Installation Information

- **All work must be performed by a licensed electrician, and must conform to all national, state, and local codes.**
- Install to provide drainage of compartment for electrical components.

## IMPORTANT SAFETY PRECAUTIONS (continued)

### General Installation Information

**⚠ WARNING** — Pumps improperly sized or installed or used in applications other than for which the pump was intended can result in severe personal injury or death. These risks may include but not be limited to electric shock, fire, flooding, suction entrapment or severe injury or property damage caused by a structural failure of the pump or other system component.

**⚠ WARNING** — The pump can produce high levels of suction within the suction side of the plumbing system. These high levels of suction can pose a risk if a person comes within the close proximity of the suction openings. A person can be seriously injured by this high level of vacuum or may become trapped and drown. It is absolutely critical that the suction plumbing be installed in accordance with the latest national and local codes for swimming pools.



- These instructions contain information for a variety of pump models and therefore some instructions may not apply to a specific model. All models are intended for use in swimming pool applications. The pump will function correctly only if it is properly sized to the specific application and properly installed.

### General Warnings

- Never open the inside of the drive motor enclosure. There is a capacitor bank that holds a 230 VAC charge even when there is no power to the unit.
- The IntelliPro 4 pump is not submersible
- The IntelliPro 4 160 pump is capable of 174 GPM or 104 feet of head; use caution when installing and programming to limit pumps performance potential with old or questionable equipment
- The IntelliPro 4 100 pump is capable of 100 GPM or 85 feet of head; use caution when installing and programming to limit pumps performance potential with old or questionable equipment
- Code requirements for the electrical connection differ from state to state. Install equipment in accordance with the National Electrical Code and all applicable local codes and ordinances.
- Always Press the Stop button and disconnect the communication cable before performing maintenance

Blank Page

# Section 1

---

## Overview

### IntelliPro Variable Speed Pump

The IntelliPro variable speed pump is well suited for all of your pool, spa, cleaner, waterfall and other water application. Using the control panel, IntelliPro can use one of the four selectable preset speeds or the pump speed can be adjusted to run at a specific speed. The IntelliPro pump out performs all conventional pumps in its class. Advanced energy conservation features ensure that your filtration system is operating at peak efficiency.

### IntelliPro models

There are two IntelliPro models which operate identically with the exception of the maximum flow rate:

- IntelliPro 160 operates at a maximum system flow of 160 gallons per minute (GPM)
- IntelliPro 100 operates at a maximum system flow of 100 gallons per minute (GPM)

The IntelliPro variable speed pump can operate from 400 RPM to 3450 RPM with preset speeds of 750, 1500, 2350, and 3110 RPM. The pump can be adjusted from the control panel to run at any speed between 400 RPM to 3450 RPM for different applications. The IntelliPro pump control panel alarm LED warns the user against under and over voltage, high temperature, over current and freeze protection.

### External Control

The IntelliPro can communicate with an IntelliTouch system or IntelliComm via a two-wire RS-485 communication cable for remote speed control.

IntelliPro variable speed pump

## Features

- Adjusts to various pool sizes
- Prevents thermal overload
- Detects and prevents damage from under and over voltage conditions
- Protects against freezing
- Communicates with the Pentair IntelliTouch system via a two-wire cable connection
- Easy to use operator control panel
- Operator control panel buttons for speed control
- Built-in strainer pot and volute
- Ultra energy-efficient TEFC Square Flange Motor
- Compatibility with most cleaning systems, filters, and jet action spas
- Driver assembly features permanent magnet synchronous motor
- Heavy-duty, durable construction designed for long life
- UL approval

## IntelliPro Motor Assembly

The IntelliPro three-phase six-pole motor operates at 3400 RPM (at 92% efficiency) and 1000 RPM (at 90%). The motor assembly is continually cooled by an external fan. Dual seals on the motor shaft and at the fan assembly seal the entire motor from any moisture from entering the motor assembly. For added protection, a slinger located in front of the main shaft seal assists in slinging water away from the shaft opening in the flange.

## IntelliPro Drive Assembly and Control Panel

The IntelliPro drive assembly consists of an operator control panel and the system electronics that drive the motor. The drive microprocessor controls the motor by changing the frequency of the current it receives together with changing the voltage to control the rotational speed.

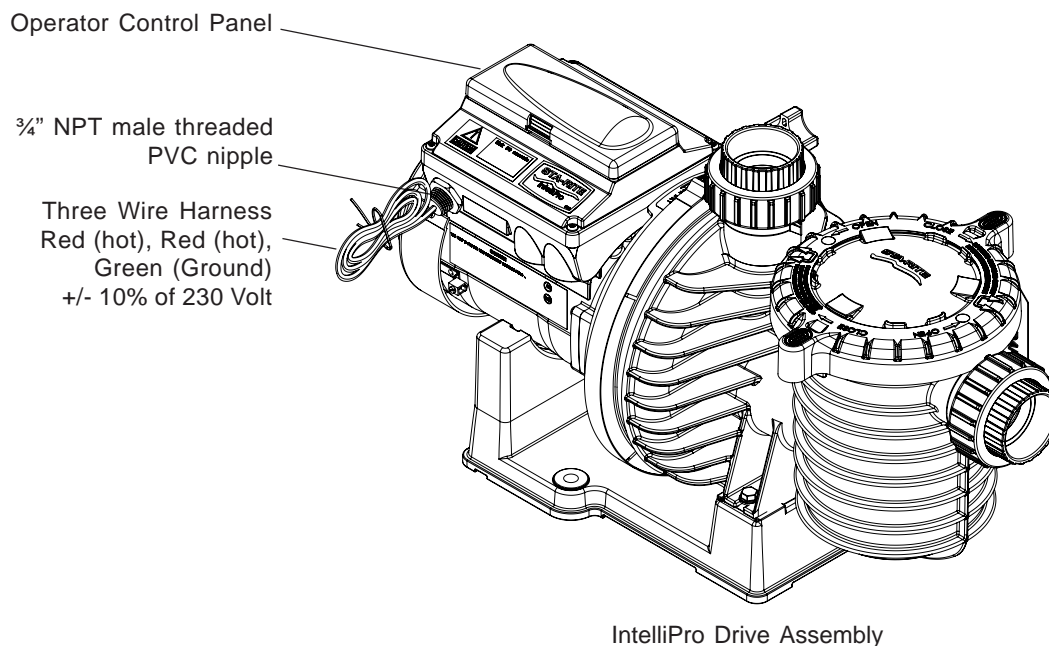

### IntelliPro Motor Features

- Permanent Magnet Synchronous Motor (PMSM)
- High efficiency (3400 RPM 92% and 1000 RPM 90%)
- Superior speed control
- Operates at lower temperatures due to high efficiency
- Same technology as deployed in hybrid electric vehicles
- Designed to withstand outdoor environment
- Totally enclosed fan cooled
- Three-phase motor
- 56 Square Flange
- Six-Pole
- Low noise

## IntelliPro Operator Control Panel

The IntelliPro operator control panel provides manual speed controls for the pump. There are four preset speed buttons that can be selected. The Up and Down button is used to adjust the pump speed. The selected speed can be saved and assigned to one of the speed buttons.

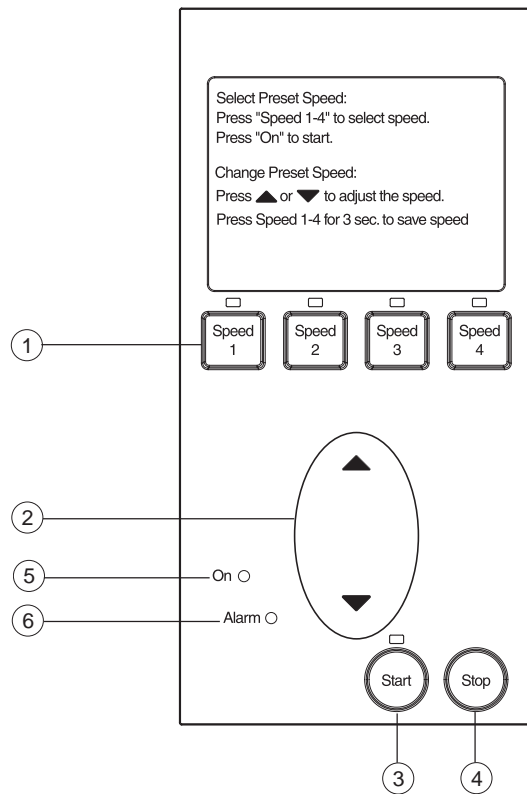

### Controls and LEDs

- ① **Speed 1, Speed 2, Speed 3, and Speed 4 button/LED:** Press one of the speed buttons to select the desired preset pump speed. The pump preset speeds are: Speed 1 (750 RPM), Speed 2 (1500 RPM), Speed 3 (2350 RPM), and Speed 4 (3110 RPM). The speed button LED is on when the selected button is pressed. If the pump is running and the Up/Down button is used to adjust the speed, the selected speed LEDs will go off. For more about using the speed buttons, see page 7.
- ② **Up/Down button:** While the pump is running, press the Up or Down button to increase or decrease the pump speed. To save the new pump speed, press any one of the four speed buttons for three seconds to assign the speed to the selected button (the LED will be on). Four adjusted pump speeds can be assigned to the speed buttons. When the pump is using an adjusted speed and the pump is powered down, the next time the pump is powered up the pump will use the same speed. For more about using the Up/Down button, see page 7.
- ③ **Start button/LED:** Starts the pump using a selected or adjusted speed. This LED is on when the pump is running.
- ④ **Stop button:** Press this button to stop the pump.
- ⑤ **On LED:** This green power LED is on when IntelliPro is powered up.
- ⑥ **Alarm LED:** This LED is on when an error condition occurs. This green LED will flash a certain number of times indicating a specific error condition. For the alarm LED flash sequence, refer to "Alarm LED Sequence," on page 27.



# Section 2

## Installation

This section describes how to install the IntelliPro pump.

**IMPORTANT! Only qualified, licensed personnel should install pump and wiring.**

- Pump mount must be located away from corrosive or flammable chemicals.

### Before installation

**Ventilation:** Allow enough ventilation to maintain air temperature at less than the maximum ambient temperature rating (Max. Amb.) listed on the motor model plate. If this pump is installed in an enclosure or pump house, the enclosure must have adequate ventilation and air circulation to keep the temperature in the enclosure at or below the rated ambient temperature for the motor whenever the pump is running.

- Solid, level, rigid, vibration free, and non-combustible. (To reduce vibration and pipe stress, bolt pump to mount.)
- Allow pump suction inlet height to be as close to water level as possible
- Allow use of short, direct suction pipe (To reduce friction losses)
- Allow for gate valves in suction and discharge piping
- Have adequate floor drainage to prevent flooding
- Be protected from excess moisture
- Allow adequate access for servicing pump and piping

**⚠ WARNING!** Fire and burn hazard. Modern motors run at high temperatures. To reduce the risk of fire, do not allow leaves, debris, or foreign matter to collect around the pump motor. To avoid burns when handling the motor, let it cool for 20 minutes before trying to work on it.

**NOTICE:** Use Teflon tape or Plasto-Joint Stik (Lake Chemical Co., Chicago, Illinois) for making all threaded connections to the pump. Do not use pipe dope; pipe dope will cause stress cracking in the pump.

**NOTICE:** Pump suction and discharge connections have molded in thread stops. DO NOT try to screw pipe in beyond these stops.

### Teflon Taping Instructions

- Use only new or clean PVC pipe fittings
- Wrap male pipe threads with one to two layers of Teflon tape. Cover entire threaded portion of pipe
- Do not overtighten or tighten past thread stop in pump port!
- If leaks occur, remove pipe, clean off old tape, rewrap with one to two additional layers of tape and remake the connection
- Support all piping connected with pump!

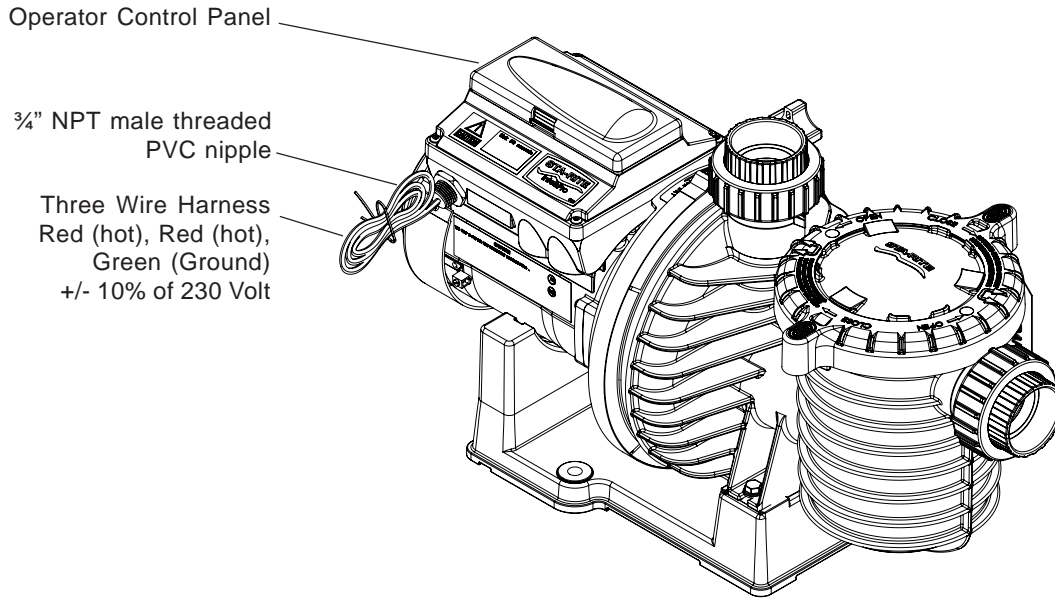

IntelliPro Drive Assembly

**NOTE:** Port threads are: Internal - 2" NPT for direct connection to pipe. External - 3-1/4" Buttress. Fits Sta-Rite U11-200P Union Collar for quick disconnect pipe connection. See Page 14 for Union Kits.

## Piping

Use at least 2" IPS PVC (51mm) pipe. Increase size if a long run is needed. To avoid strains on the pump, support both suction and discharge pipes independently. Place these supports near the pump. To avoid a strain left by a gap at the last connection, start all piping at the pump and run pipe away from the pump. Never use a suction pipe smaller than pump suction connection. To avoid air locking, slope suction pipe slightly upward toward the pump.

**NOTICE:** To prevent flooding when removing pump for service, all flooded suction systems must have gate valves in suction and discharge pipes.

## Fittings

- Fittings restrict flow; for best efficiency use fewest possible fittings.
- Avoid fittings which could cause an air trap.
- Pool fittings must conform to International Association of Plumbing and Mechanical Officials (IAPMO) standards.
- Use only non-entrapping suction fitting or double suction.

## Wiring the IntelliPro

To connect the IntelliPro to an AC power source:

1. Make sure all electrical breakers and switches are turned off before wiring motor.
2. Make sure that the wiring voltage is 230 VAC.
3. Use #12 AWG for wire runs up to 100 feet and #10 AWG for lengths longer than 100 feet. When in doubt use a heavier gauge (larger diameter) wire. Heavier gauge will allow the motor to run cooler and more efficient.
4. Make sure all electrical connections are clean and tight.
5. Cut the wires to the appropriate length so they do not overlap or touch when connected.
6. Permanently ground the motor using the green ground wire, as shown below. Use the correct wire size and type specified by National Electrical Code. Make sure the ground wire is connected to an electrical service ground.
7. Bond the motor to the pool structure in accordance with the National Electrical Code. Use a solid No. 8 AWG or larger copper conductor (No. 6 or larger in Canada). Run a wire from the external bonding lug to the pool bonding structure, as shown below.
8. Permanently connect the pump to a non-GFCI circuit breaker, two-pole timer or relay in an automation controller. Be sure that no other lights or appliances are on the same circuit.

**NOTE: The IntelliPro will not function properly when powered from a GFCI device.**

**NOTE: When the IntelliPro is started and stopped by removing power with a relay or timer, a two-pole device should be used to apply and remove power to both of the red power leads.**

9. For wiring pinouts for the communications port, see page 12.

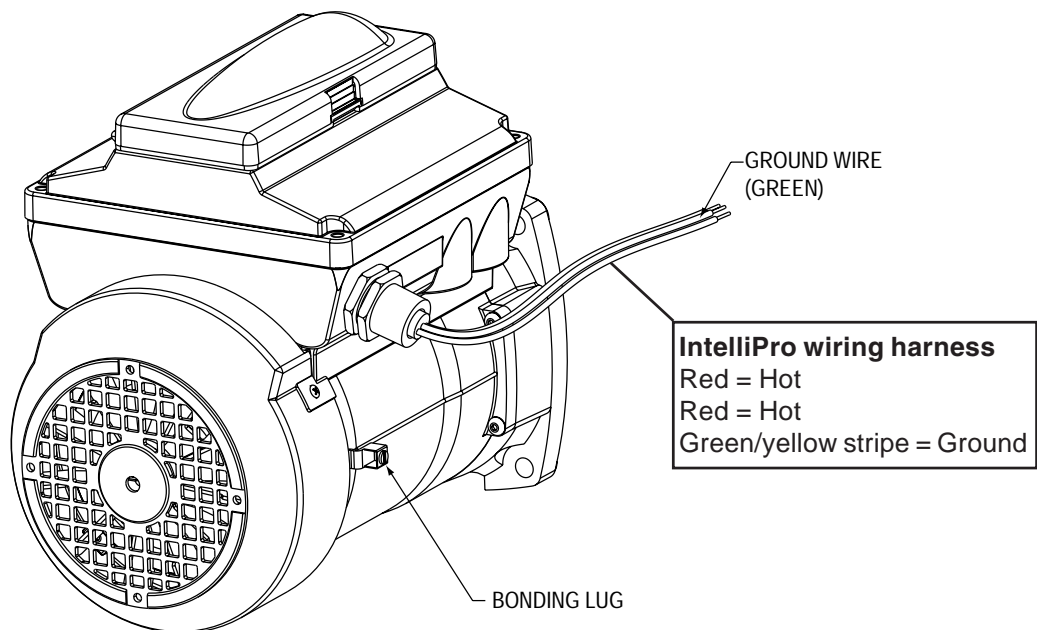

## External Control with IntelliComm Communication Center

The IntelliPro can be remotely controlled by the Pentair IntelliComm Communication Center using the communications cable (P/N 350122). The IntelliComm provides four pairs of input terminal connections. These inputs are actuated by either 15 - 240 VAC or 15 - 100 VDC. Using the device's inputs, the programmed IntelliPro pump speeds can be controlled.

If more than one input is active the highest number will be communicated to the IntelliPro pump. The IntelliComm will always communicate to pump address 1.

The following table shows the wiring terminal descriptions for IntelliComm.

### External Control

Terminal number	Terminal name	Voltage	Maximum current	Phase type	Frequency
1-2	Power supply	100 - 240 VAC	100 mA	1 Input	50/60 Hz
3-4	Program 1	15 -240 VAC or 15 - 100 VDC	1 mA	1 Input	50/60 Hz
5-6	Program 2	15 -240 VAC or 15 - 100 VDC	1 mA	1 Input	50/60 Hz
7-8	Program 3	15 -240 VAC or 15 - 100 VDC	1 mA	1 Input	50/60 Hz
9-10	Program 4	15 -240 VAC or 15 - 100 VDC	1 mA	1 Input	50/60 Hz
11 12	RS-485 + Data: Yellow - Data: Green	-5 to +5 VDC	5 mA	1 Output	N/A
	Ground				



IntelliComm Communication Center

## Connecting IntelliPro 4 to an EasyTouch System

The IntelliPro 4 can be controlled by an EasyTouch system via the RS-485 communication cable (P/N 350122). In this configuration, EasyTouch starts, stops and controls the speed of the IntelliFlo 4 pump. When the EasyTouch does this, it rewrites the IntelliFlo 4 memory, which can take several seconds. This causes a delay after a command is given on the EasyTouch control panel until the IntelliFlo 4 physically responds.

The IntelliPro 4 control panel is disabled when communicating with the EasyTouch system. Note that IntelliTouch will not start communicating with the IntelliFlo 4 until the pump is assigned to a circuit. The IntelliPro 4 default pump address is one which is the only address that works with EasyTouch. See page 6 for details about how to check the address and change if necessary. For more information, refer to the EasyTouch User's Guide (P/N 520584).

To connect the IntelliPro 4 communication cable to EasyTouch load center:

1. **⚠ CAUTION - Switch the main power off to the EasyTouch load center.**
2. Unlatch the two enclosure door spring latches, and open the door.
3. Remove the two retaining screws securing the high voltage cover panel, and remove it from the enclosure.
4. Loosen the two access screws securing the control panel.

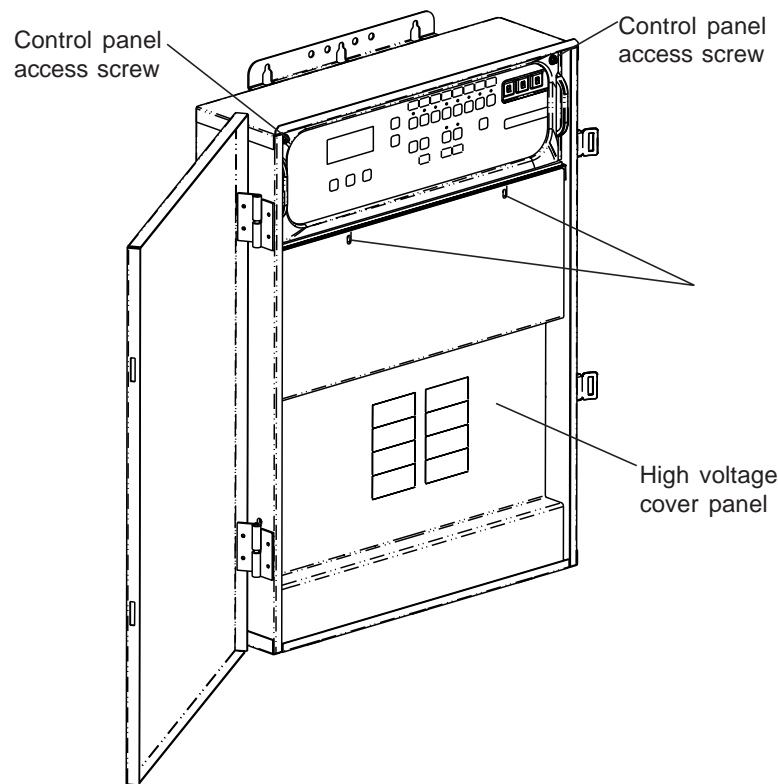

EasyTouch Load Center (front view)

5. Lower down the hinged control panel to access the EasyTouch motherboard.
6. Route the communication cable into the lower plastic grommet, up through the low voltage raceway to the EasyTouch load center motherboard.

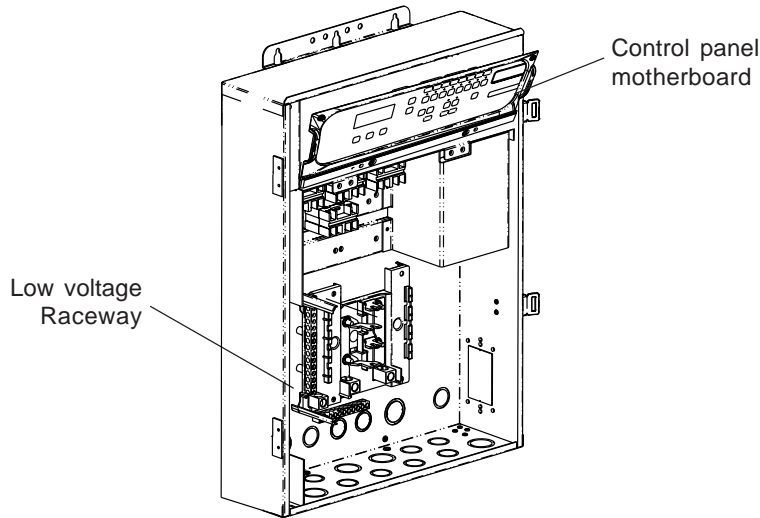

7. Strip back the cable conductors ¼ inch. Insert the two wires into the screw terminals on the board. Secure the wires with the screws.
8. **EasyTouch to IntelliPro 4 pin configuration:**
  - IntelliPro 4: Connect pin 6 (green) to EasyTouch screw terminal pin 2 (green)
  - IntelliPro 4: Connect pin 7 (yellow) to EasyTouch screw terminal pin 3 (yellow)

EasyTouch (J20)  
screw terminal

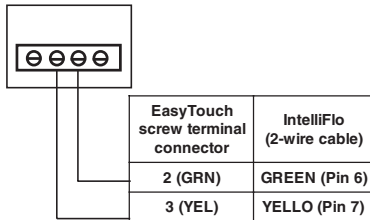

Pin configuration

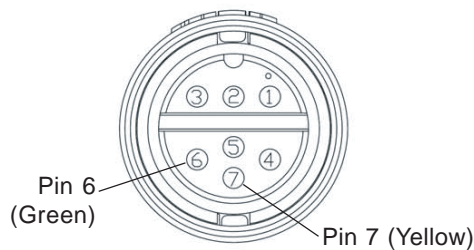

IntelliFlo connector pin configuration

9. Insert the screw terminal onto the EasyTouch **COM-PORT (J20)** board connector. *Note: Multiple wires may be inserted into a single screw terminal.*

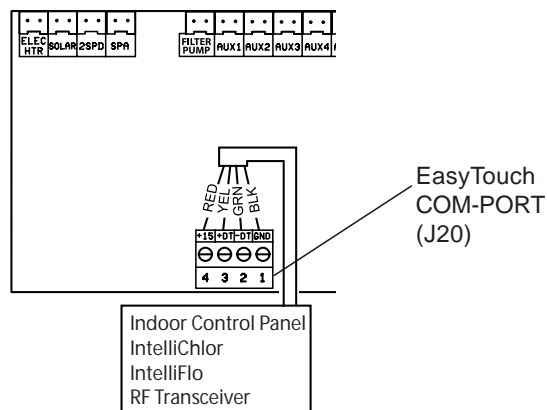

10. Close the control panel into its original position and secure it with the two access screws.
11. Install the high voltage cover panel and secure it with the two retaining screws.
12. Close the EasyTouch load center front door. Fasten the two spring latches.
13. Switch the power on to the EasyTouch load center.

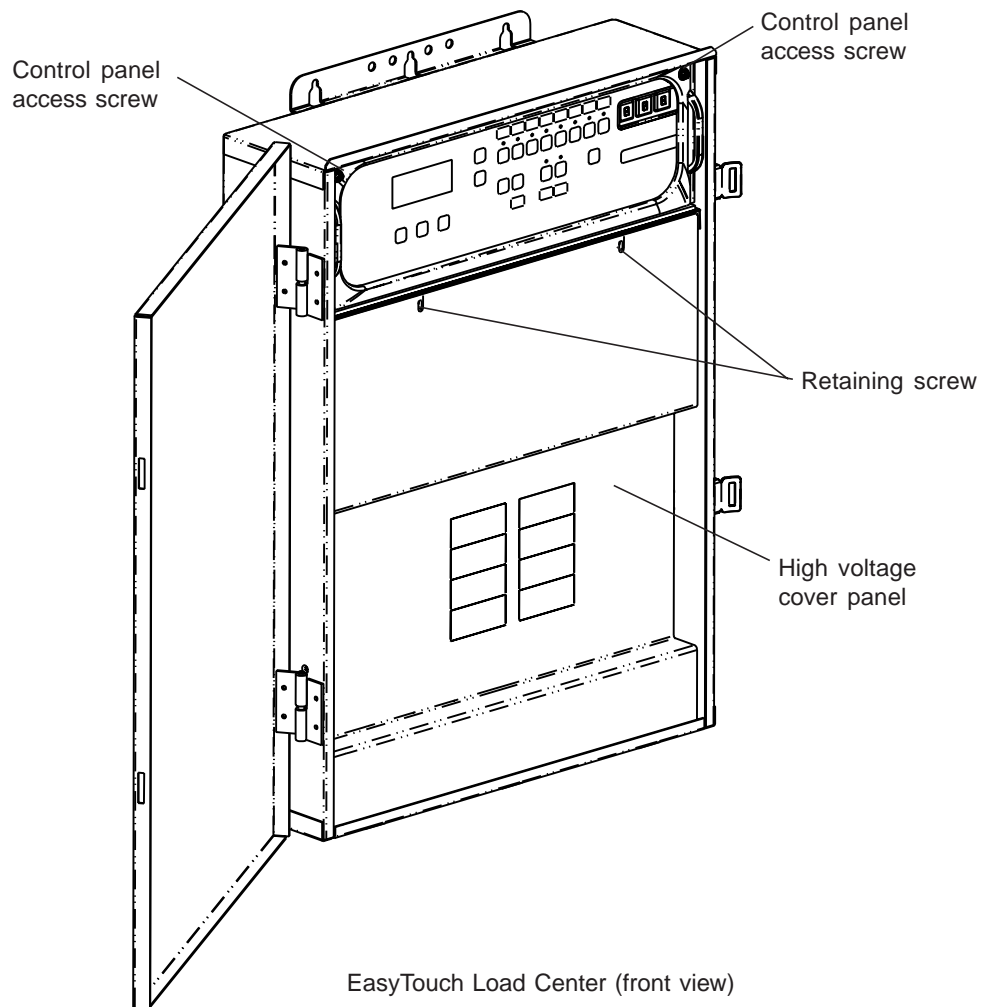

## Connecting IntelliPro 4 to an IntelliTouch System

The IntelliPro 4 can be controlled by an IntelliTouch system via the RS-485 communication cable (P/N 350122). In this configuration, IntelliTouch starts, stops and controls the speed of the IntelliPro 4 pump. When the IntelliTouch does this, it rewrites the IntelliPro 4 memory, which can take several seconds. This causes a delay after a command is given on the IntelliTouch control panel until the IntelliPro 4 physically responds.

The IntelliPro 4 control panel is disabled when communicating with the IntelliTouch system. Note that IntelliTouch will not start communicating with the IntelliPro 4 until the appropriate pump address is assigned to a circuit. The IntelliPro 4 default pump address is one. See page 6 for details about how to check the address and change if necessary. For more information, refer to the IntelliTouch User's Guide (P/N 520102).

To connect the IntelliPro 4 communication cable to IntelliTouch load center:

1. **⚠ CAUTION - Switch the main power off to the IntelliTouch load center.**
2. Unlatch the IntelliTouch load center front door spring latches, and open the front door.
3. Remove the cover-panel screws securing the high voltage cover-panel, and remove it from the enclosure.
4. Loosen the two control panel access screws and fold down the outdoor control panel.
5. Insert the two-wire cable into plastic grommet on the bottom of the enclosure and route the wire up through the low voltage raceway to the Personality board.

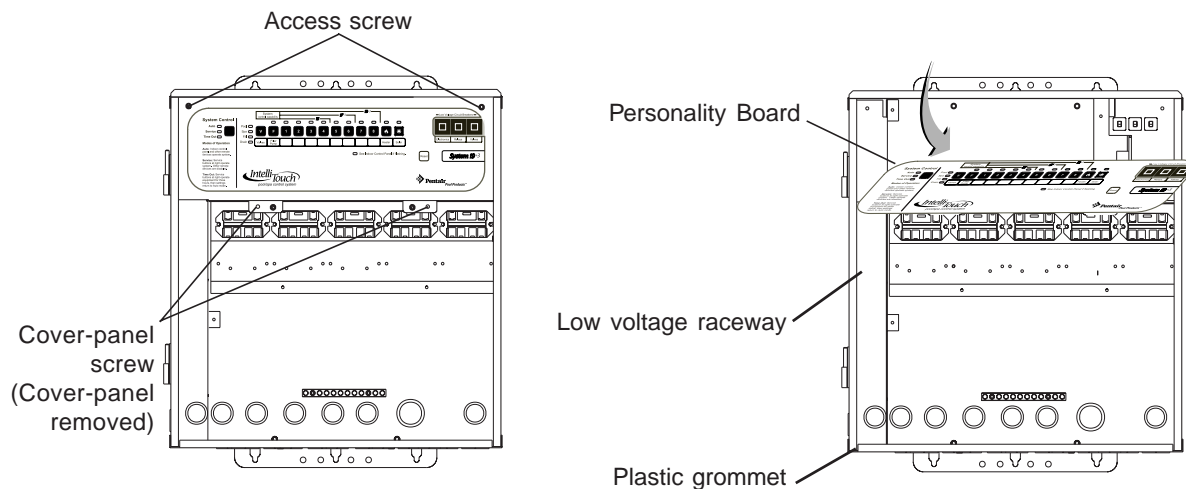

IntelliTouch Load Center



### Connecting IntelliPro 4 to IntelliTouch (Continued)

- Strip back the cable conductors ¼". Insert the wires into the either of the **COM PORTS (J7 and J8)** screw terminals located on the left side of the Personality board. Secure the wires with the screws. For wiring details, refer to the pin configuration shown below. *Note: Multiple wires may be inserted into a single screw terminal.*

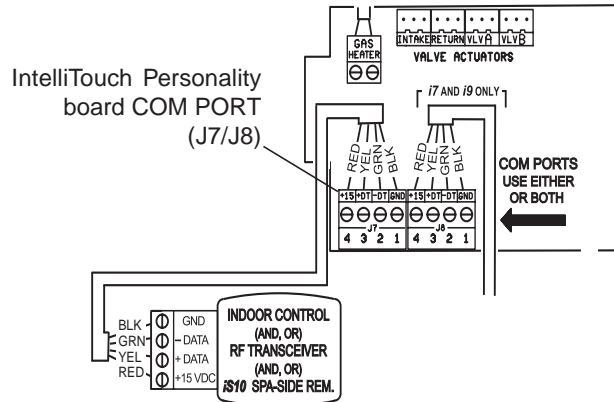

### Pin Configuration for IntelliPro 4 to IntelliTouch:

- IntelliPro 4: Connect pin 6 (green) to IntelliTouch screw terminal pin 2 (green)
- IntelliPro 4: Connect pin 7 (yellow) to IntelliTouch screw terminal pin 3 (yellow)

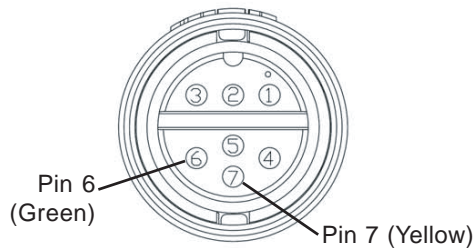

IntelliFlo 4 cable pin configuration

IntelliTouch  
COM PORT (J7/J8)  
screw terminal

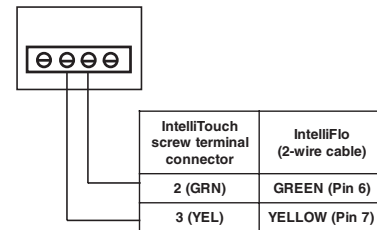

Pin configuration

- Close the IntelliTouch control panel and secure it with the two access screws.
- Install the high voltage panel cover and secure it with the two retaining screws.
- Close the load center front door and secure with the two latches.
- Switch power on to the IntelliTouch load center.

Blank Page

# Section 3

## Operation

This section describes how to use the IntelliPro pump control panel.

**⚠ CAUTION** - NEVER run pump dry. Running pump dry may damage seals, causing leakage and flooding. Fill pump with water before starting motor.

Before removing trap cover:

1. STOP PUMP before proceeding.
2. CLOSE GATE VALVES in suction and discharge pipes.
3. RELEASE ALL PRESSURE from pump and piping system.
4. NEVER tighten or loosen clamp while pump is operating!

**⚠ WARNING** - If pump is being pressure tested, be sure pressure has been released before removing trap cover.

Do not block pump suction. To do so with body may cause severe or fatal injury. Small children using pool must ALWAYS have close adult supervision.

**Fire and burn hazard:** Modern motors run at high temperatures. To reduce the risk of fire, do not allow leaves, debris, or foreign matter to collect around the pump motor. To avoid burns when handling the motor, let it cool for 20 minutes before trying to work on it. An automatic internal cutoff switch protects the motor from heat damage during operation.

**NOTICE:** Maximum ambient temperature for motor operation must not exceed maximum ambient temperature rating on motor model plate.

### Setting the pump preset speed

IntelliPro operates using one of the preset speeds. Use the speed buttons to select the preset speeds.

#### To set the pump speed

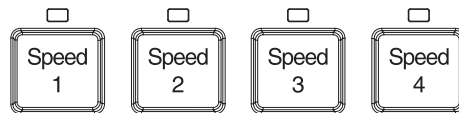

1. Ensure that the pump is powered on and the green power LED is on.
2. Press the desired speed button (1- 4) for less than three seconds to select the preset pump speed. When the selected speed button is pressed, the LED is on. The pump preset buttons and speeds are:

**Speed 1 button - 750 RPM**

**Speed 2 button - 1500 RPM**

**Speed 3 button - 2350 RPM**

**Speed 4 button - 3110 RPM**

3. Press the **Start** button to start the pump using the selected speed if necessary.

## Adjusting the pump speed

IntelliPro 4 can be adjusted to run at any speed between 400 RPM and 3450 RPM.

### To adjust the pump speed

1. Ensure that the pump is powered on and the green power LED is on.
2. Press the **Start** button to start the pump if the pump is not running.
3. Press the **UP/Down** button to increase or decrease the pump speed.
  - **10 RPM increments:** Press and quickly release the **Up/Down** button to increase or decrease the speed in 10 RPM increments.
  - **20 RPM increments:** Press and hold the **Up/Down** button to continuously increase or decrease the pump speed.
4. **Saving an adjusted speed:** To save the newly adjusted pump speed, press the desired speed buttons to assign the current speed. Four new pump speeds can be assigned to Speed buttons (1-4).
5. Press the **Speed** button that is assigned to the adjusted speed.

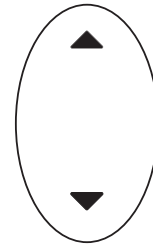

Up/Down button

## Starting the pump

### To start the pump

1. Ensure that the pump is powered on and the green power LED is on.
2. Press the **Start** button (LED on) to start the pump.

*Note: When the pump is using a modified speed and is powered down, the next time the pump is powered up, the pump will use that same speed.*

## Stopping the pump

### To stop the pump

- Press the **Stop** button to stop the pump.
- Note: The pump can automatically restart if the communication cable is connected.*

## Setting the pump communication address

The IntelliPro 4 communication address can be set to numbers 1, 2, 3 or 4.

### To set the address

1. Be sure the pump is powered on (green LED on) but not running.
2. Press and hold the **Start** and **Stop** button simultaneously for *three* seconds. The red Alarm LED should start flashing. The LED for the currently active communication address should illuminate.
3. Release the **Start** and **Stop** buttons.
4. The active communications address is indicated by the LED's above the Speed buttons; Speed 1 for address 1, Speed 2 for address 2 etc.

## Setting the pump communication address (Continued)

5. Change the active address by pressing the appropriate Speed button (Speed 1, Speed 2, Speed 3 or Speed 4) while the Alarm LED is flashing.
6. Once the desired address has been selected, press and hold the **Start** and **Stop** buttons again. The Alarm LED will stop flashing and the Speed LED for the previously selected run speed will illuminate.
7. Release the **Start** and **Stop** buttons.

## Resetting the pump to factory defaults

The IntelliPro pump can be reset to the factory default settings. All previously adjusted pump speeds that were saved will be erased.

To reset the pump to the factory default settings:

1. Ensure that the pump is powered on and the green power LED is on.
2. Press the **Stop** button to stop the pump.
3. Press and hold all of the four **Speed** buttons simultaneously for three seconds. Power off the drive and reenergize. The default settings will be in effect.

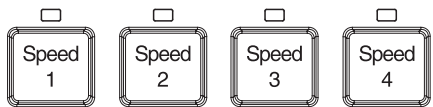

## Priming the pump for the first time or after service

Before the IntelliPro pump is started for the first time it must be primed. To prime a pump means filling the pump and suction pipe with water. This process evacuates the air from all the suction lines and the pump. It may take several minutes to prime depending on the depth of water, pipe size and length. It is easier to prime a pump if you allow all the air to escape from the pump and pipes. The water cannot enter unless the air can escape. Pumps do not hold prime, the pool piping system has that task.

**CAUTION** - To avoid permanent damage to the IntelliPro pump, before starting the pump, fill the IntelliPro housing strainer with water so that the pump will prime correctly. If there is no water in the stainer the pump will not prime.

- NEVER run the pump dry! Running the pump dry may damage the seals, causing leakage and flooding!
- Do not add chemicals to the system directly in front of pump suction. Adding undiluted chemicals may damage the pump and will void the warranty.
- Open gate valves before starting system.
- Pump will prime itself when used in flooded suction system.
- Be sure to release all air from filter and piping system.
- The IntelliPro pump is a variable speed pump. Typically the lower speeds are used for filtration and heating. The higher speeds can be used for spa jets, water features, and priming.

**CAUTION** - Before starting this procedure, first read the following.  
Before removing the pump lid:

1. Press the Stop button if the pump is running before proceeding.
1. Disconnect the communication cable from the pump.
2. Close the gate valves in suction and discharge pipes.
3. Release all pressure from pump and piping system.
4. Never tighten or loosen the clamp while the pump is operating.

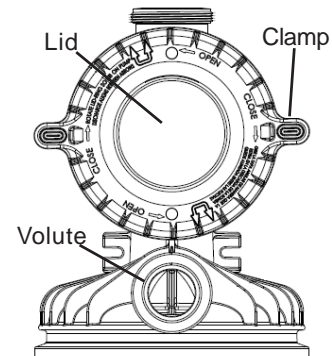

**WARNING!** If the pump is being pressure tested, release all pressure before removing the trap cover. Do not block the pump suction while the pump is running. If a body part blocks the pump suction it may cause severe or fatal injury. Small children using the pool must ALWAYS have close adult supervision.

**WARNING! FIRE and BURN HAZARD** - The pump motor may run at a high temperatures. To reduce the risk of fire, do not allow leaves, debris, or foreign matter to collect around the pump motor. To avoid burns when handling the motor, shut off the motor and allow it to cool for 20 minutes before trying to work on it. The IntelliPro provides an automatic internal cutoff switch to protect the motor from heat damage during operation.

## Priming the pump for the first time or after service (Continued)

### Priming the Pump

- Release all pressure from filter, pump, and piping system; see the filter owner's manual.
- In a flooded suction system (water source higher than pump), the IntelliPro pump will prime itself when suction and discharge valves are opened.
- If the IntelliPro pump is not in a flooded suction system, unscrew and remove lid cover; fill the and pump with water.
- Do not lubricate the trap cover o-ring. The original equipment o-ring contains a permanent internal lubricant.

**NOTICE:** If you replace the o-ring with a non-internally lubricated o-ring, you may need to apply a silicone based lubricant.

- Clean and inspect o-ring; reinstall on trap cover.
- Replace trap cover on trap; turn clockwise to tighten cover.

**NOTICE:** Tighten the pump lid by hand only (no wrenches)!

Pump should prime now. Priming time will depend on vertical length of suction lift and horizontal length of suction piping. If pump does not prime, make sure that all valves are open, suction pipe end is under water, pump suction is below water level, and that there are no leaks in suction pipe.

To prime the IntelliPro pump:

1. Turn the pump clamp and lid in a counterclockwise direction until it stops and remove them.
2. Fill the pump strainer pot with water.
3. Reinstall the pump clamp and lid onto the strainer pot. The pump is now ready to prime.
4. Make sure all electrical connections are clean and tight.
5. Open the air release valve on the filter, and stand clear of the filter.
6. Switch the IntelliPro pump on at the circuit breaker. Ensure that the green power light is on.
7. Press the **Speed 1** button to select the pump speed of 750 RPM.
8. Press the **Start** button to start the pump. Use the **Up/Down** button to increase the speed as necessary to prime the pump.
9. When water comes out of the air release valve, close the valve. The system should now be circulating water back to the pool without air bubbles showing in either the hair and lint pot or at the pool return fittings.
10. Use the **Up/Down** button to adjust the operating speed as desired.

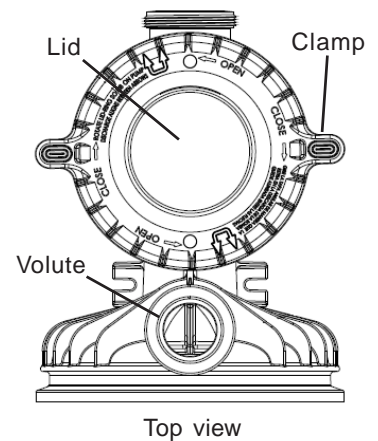

## Draining Pump

**⚠ CAUTION** - To avoid dangerous or fatal electrical shock hazard, turn OFF power to motor before draining pump.

1. Pump down water level below all inlets to the pool.
2. Remove the trap cover and use low pressure air to blow the accumulated water from the piping system. Lugs have been provided on the trap lid to use a lever or pry bar for loosening.
3. Cap the inlet piping after draining to keep water out of the pipes.
4. To prevent the pump from freezing, remove the trap cover and drain the tank body through the drain plugs (Key No. 19). Clean the pump and trap basket thoroughly; replace the trap cover.

**NOTICE:** Hand tighten the trap cover - **Do not use a wrench!** Use a rubber mallet only if necessary to remove the cover - If the pump is not anchored, use caution not to break or damage the attached piping.

5. Be sure the motor is kept dry and covered.

## Storage/Winterizing

**⚠ WARNING** - Explosion hazard. Purging the system with compressed air can cause components to explode, with risk of severe injury or death to anyone nearby. Use only a low pressure (below 5 PSI), high volume blower when air purging the pump, filter, or piping.

**NOTICE:** Allowing the pump to freeze will damage pump and void warranty!

**NOTICE:** Do not use anti-freeze solutions (except propylene glycol) in your pool/spa system. Propylene glycol is non-toxic and will not damage plastic system components; other anti-freezes are highly toxic and may damage plastic components in the system.

- Drain all water from pump and piping when expecting freezing temperatures or when storing pump for a long time (see instructions below).
- Keep motor dry and covered during storage.
- To avoid condensation/corrosion problems, do not cover pump with plastic.

### For outdoor/unprotected installations:

1. Gravity drain system as far as possible.
2. Protect areas which retain water with non-toxic propylene glycol antifreeze (“RV antifreeze”).
3. Enclose entire system in a weatherproof enclosure.
4. To avoid condensation/corrosion damage, allow ventilation; do not wrap system in plastic.
5. Use a 40% propylene glycol/60% water solution to protect pump to -50°F (-46°C).



## Startup For Winterized Equipment

1. Remove any temporary weather protection placed around system.
2. Follow the filter manufacturer's instructions for reactivation of the filter.
3. Inspect all electrical wiring for damage or deterioration over the shutdown period. Have a qualified serviceman repair wiring as needed.
4. Inspect and tighten all watertight connections.
5. Open all valves in suction and return piping.
6. Remove any winterizing plugs in piping system.
7. Drain all antifreeze from system.
8. Close all drain valves and replace all drain plugs in piping system.
9. Prime pump according to instructions on Page x.

## Pump Service

- Pump should only be serviced by qualified personnel.
- For best results, use only genuine Sta-Rite factory parts.
- Be sure to prime pump (page 19) before starting.

 **CAUTION** - Before removing clamp or trap cover:

1. STOP PUMP before proceeding.
2. DISCONNECT THE COMMUNICATIONS CABLE from the pump.
3. CLOSE GATE VALVES in suction and discharge pipes.
4. RELEASE ALL PRESSURE from pump and piping system.
5. NEVER tighten or loosen clamp while pump is operating!

 **WARNING** - To avoid dangerous or fatal electrical shock hazard, turn OFF power to motor before working on pump or motor. No lubrication or regular maintenance is needed beyond reasonable care and periodic cleaning of the strainer basket.

Blank Page

## Section 4

# User Maintenance

The following information describes how to service and maintain the IntelliPro pump.

### Pump Strainer Basket

The strainer, sometimes referred to as the “Hair and Lint Pot,” is in front of the pump. Inside there is a basket which must be kept clean of leaves and debris at all times. View the basket through the top see through lid to inspect for leaves and debris.

Regardless of the length of time between filter cleaning, it is most important to visually inspect the hair and lint pot basket at least once a week. A dirty basket will reduce the efficiency of the filter and possibly the heater.

**⚠ WARNING** — **DO NOT** open the strainer pot if pump fails to prime or if pump has been operating without water in the strainer pot. Pumps operated in these circumstances may experience a build up of vapor pressure and may contain scalding hot water. Opening the pump may cause serious personal injury. In order to avoid the possibility of personal injury, make sure the suction and discharge valves are open and that the strainer pot is cool to the touch, then open with extreme caution.

**⚠ CAUTION** — To prevent damage to the pump and filter and for proper operation of the system, clean pump strainer and skimmer baskets regularly.

### Pump Strainer Basket Service

If the IntelliPro pump is installed below the water level of the pool, close the return and suction lines before opening the hair and lint pot on the pump.

1. Press the **Stop** button to stop the pump and switch off the pump at the circuit breaker.
2. Disconnect the communication cable from the IntelliPro pump.
3. Relieve pressure in the system.
4. Turn the clamp and lid in a counterclockwise direction until it stops.
5. Remove the clamp and lid.
6. Remove the basket and put the debris into the trash and rinse out the basket. If the basket is cracked, replace the basket.
7. Replace the basket and fill the pump pot and volute with water up to the inlet port.
8. Clean the cover, o-ring, and sealing surface of the pump pot. Grease the o-ring with Teflon or silicone lubricant.
9. Reinstall the lid by placing the clamp and the lid on the pot.

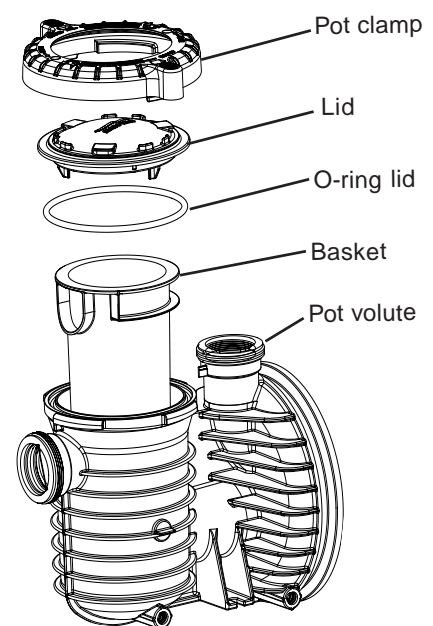

## Pump Strainer Basket Service (Continued)

10. Ensure that the lid o-ring is properly placed. Seat the clamp and lid then turn clockwise until the handles are horizontal as shown.
11. Reconnect the communication cable to the pump if required.
12. Switch the power ON at the circuit breaker. Reset the pool time clock to the correct time.

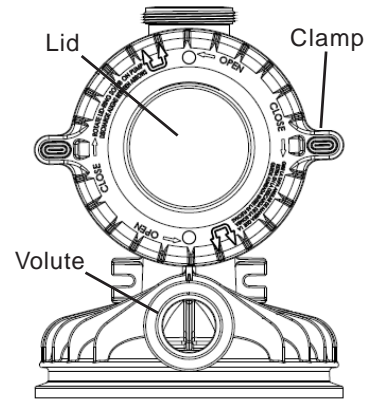

**WARNING** — FILTER OPERATES UNDER HIGH PRESSURE. WHEN ANY PART OF THE CIRCULATING SYSTEM (e.g., LOCK RING, PUMP, FILTER, VALVES, ETC.) IS SERVICED, AIR CAN ENTER THE SYSTEM AND BECOME PRESSURIZED. PRESSURIZED AIR CAN CAUSE THE LID TO BLOW OFF WHICH CAN RESULT IN SEVERE INJURY, DEATH, OR PROPERTY DAMAGE. TO AVOID THIS POTENTIAL HAZARD, FOLLOW THESE INSTRUCTIONS.

13. Prime the pump. See page 19 for details.

## Motor Service

1. **Protect from heat:**
  - Shade the motor and controller from the sun.
  - Any enclosure must be well ventilated to prevent overheating. Particular attention should be paid to the motor fan cover and the cooling fins between the drive and the motor.
  - Provide ample cross ventilation.
2. **Protect against dirt:**
  - Protect from any foreign matter or splashing water.
  - Do not store (or spill) pool chemicals near the motor.
  - Avoid sweeping or stirring up dust near the motor while it is operating.
  - If a motor has been damaged by dirt it voids the motor warranty.
3. **Protect against moisture:**
  - Protect from splashing pool water.
  - Protect from the weather.
  - Protect from lawn sprinklers.
  - If a motor has become wet - let it dry before operating. Do not allow the pump to operate if it has been flooded.
  - If a motor has been damaged by water it voids the motor warranty.

*Note: DO NOT wrap motor and controller with plastic or other air tight materials. The motor and controller may be covered, but not wrapped in plastic, during a storm, for winter storage, etc., but never when operating, or expecting operation.*

## Winterizing

To protect the IntelliPro pump electronics from damage due to freezing conditions, the pump will switch it self on to generate internal heat when the air temperature drops below 40° F. This feature is not intended to protect the system plumbing from freezing.

1. If the air temperature drops below 40° F the water in the pump can freeze and cause damage. Freeze damage is not warrantable.
2. To prevent freeze damage follow the procedures listed below.
  - Shut off electrical power for the pump at the circuit breaker.
  - Drain the water out of the pump by removing the two thumb-twist drain plugs located at the bottom of the volute. Store the plugs in the pump basket.
  - Cover the motor to protect it from severe rain, snow and ice.
  - Do not wrap the motor in plastic. It will cause condensation and rust on the inside of the motor.

*Note:* In mild climate areas, when temporary freezing conditions may occur, run your filtering equipment all night to prevent freezing.

## Priming the pump after service

Before a system start-up, the pump and system must be manually primed. Make sure to reopen valves before operating. To prime IntelliPro, the strainer pot must be filled with water.



**CAUTION** — DO NOT run the pump dry. If the pump is run dry, the mechanical seal will be damaged and the pump will start leaking. If this occurs, the damaged seal must be replaced. ALWAYS maintain proper water level in your pool. Continued operation in this manner could cause a loss of pressure, resulting in damage to the pump case, impeller and seal.

For instructions about how to prime the IntelliPro pump, refer to “Priming the pump for the first time or after servicing,” on page 9.

Blank Page



# Section 5

## Removal and Replacement

The following information describes how to remove and install the drive assembly and to repair a worn or damaged shaft seal.

**Note: Before installing this product, read and follow all warning notices and instructions on page ii.**

### Pump Disassembly

-  **WARNING** — Always disconnect power to the pool pump at the circuit breaker and disconnect the communication cable before servicing the pump. Failure to do so could result in death or serious injury to serviceman, pool users or others due to electric shock.
-  **WARNING** — **DO NOT** open the strainer pot if pump fails to prime or if pump has been operating without water in the strainer pot. Pumps operated in these circumstances may experience a build up of vapor pressure and may contain scalding hot water. Opening the pump may cause serious personal injury. In order to avoid the possibility of personal injury, make sure the suction and discharge valves are open and strainer pot temperature is cool to touch, then open with extreme caution.
-  **CAUTION** — Be sure not to scratch or mar the polished shaft seal faces; seal will leak if faces are damaged.

Required tools:

- ½ inch open end wrench.
- 7/16 inch open end wrench.
- Flat blade screwdriver.

### Drive Assembly Removal and Installation

To remove the IntelliPro drive assembly and control panel from the pump's motor assembly:

 **WARNING** - To avoid dangerous or fatal electrical shock hazard, switch OFF power to motor before working on pump or motor.

1. Disconnect the RS-485 communication cable from the pump.
2. Open the control panel cover.

## Drive Assembly Removal and Installation (Continued)

- Remove the three Phillips head screws securing the drive to the motor assembly as shown.

**⚠ CAUTION: TO AVOID ELECTRICAL HAZARD, DO NOT REMOVE THE FOUR TAMPER PROOF BITS FROM THE MOTOR ASSEMBLY**

- Lift up the drive assembly and remove it from the motor adapter located on top of the motor assembly.

*Note: Be careful not to remove the gasket between the drive and motor, it is critical in keeping moisture out of the drive and motor. Replace the gasket if damaged. Do not reassemble with a damaged or missing gasket.*

To install the IntelliPro drive assembly onto the motor assembly:

- Make sure all electrical breakers and switches are turned off before installing the drive.
- Be sure that the gasket between the drive and motor is in place. It is critical in keeping moisture out of the drive and motor. Replace the gasket if damaged. Do not reassemble with a damaged or missing gasket.
- Verify that the three (3) orange motor post caps are in position before placing the drive on the motor assembly.
- Align the drive assembly with the motor adapter and seat the drive on the motor assembly.
- Secure and tighten the drive assembly with the three Phillips head screws.

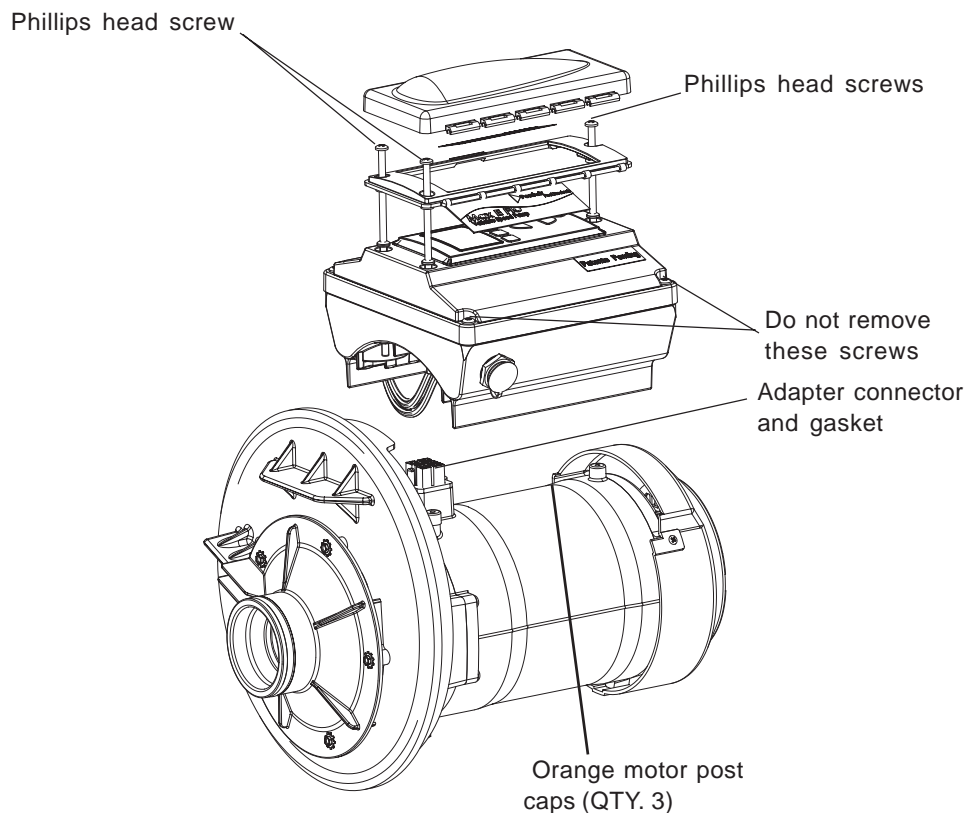



## Pump Disassembly/Removing Old Seal

**⚠️ WARNING** - To avoid dangerous or fatal electrical shock hazard, switch OFF power to motor before working on pump or motor.

**⚠️ CAUTION** - Be sure gate valves on suction and return piping are closed and release all pressure by opening all vents before starting work.

Release all pressure by opening all vents before starting.

1. Drain the pump by removing the drain plugs on the bottom of the pump body and trap body.
2. Be sure there is no pressure in the trap body. Remove the cover (unscrew by turning the handle ring counterclockwise).
3. Remove the clamp holding the pump halves together. The motor and seal plate assembly can now be pulled away from the pump body.
4. Remove the five screws and washers holding the diffuser to the seal plate. Remove the diffuser.
5. Hold the shaft with a 7/16" open-ended wrench on the motor shaft flats.
6. Unscrew the impeller from the shaft (turn counterclockwise when facing it). **Note:** *On models with an impeller screw: Remove the impeller screw (left hand thread - turn **clockwise**) and gasket before removing the impeller. Inspect the gasket for damage, cracks, etc. Replace if damaged.*
7. Pull the rotating member of the seal off the impeller sleeve - Clean the sleeve.
8. Remove the four screws holding the seal plate to the motor.
9. Place the seal plate face down on flat surface and tap out the ceramic seat.
10. Clean the seal cavity in the seal plate and clean the motor shaft.

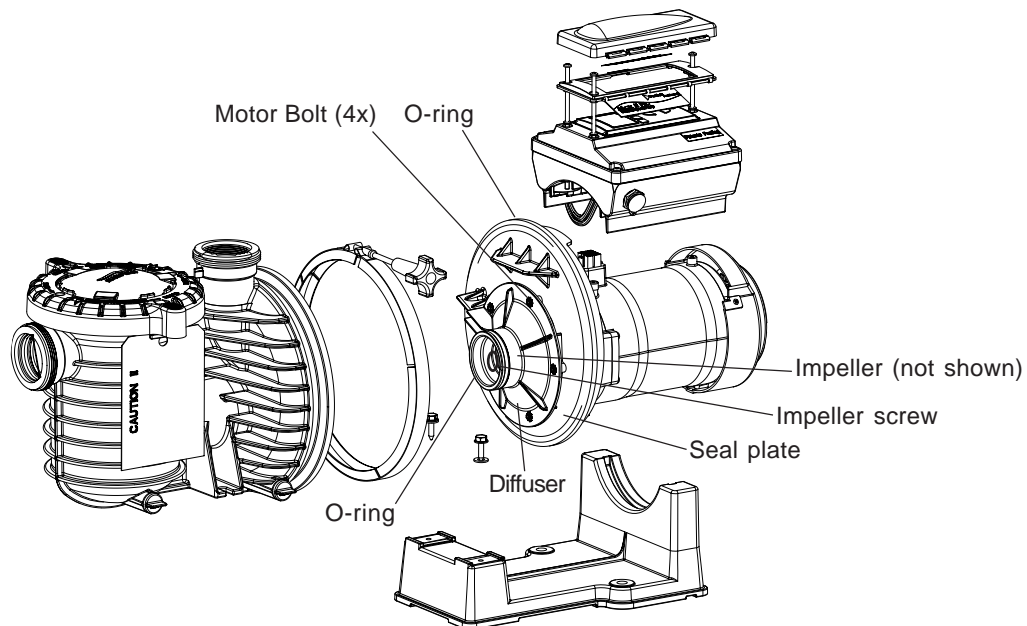

## Pump Reassembly/Installing New Seal

1. The ceramic seat must be clean and free of dirt, grease, dust, etc. Wet the outer edge of rubber cup on the ceramic seat with a small amount of liquid detergent. Press the ceramic seat into the seal plate firmly and squarely with finger pressure. See illustration below.

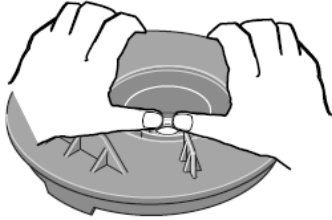

2. If the ceramic seat will not lock properly, remove it, place it face up on bench and reclean the cavity. The ceramic seat should now lock.
3. If the seat still won't lock properly, place a cardboard washer over the polished face and use a piece of 3/4" (19 mm) standard pipe for pressing purposes. **Note:** *Be sure not to scratch or mar the polished surface. This will cause the seal to leak.*
4. Remount the seal plate on the motor. Tighten the bolts to 60-80 inch-lbs. (69-92 kg/cm) torque.
5. Apply a small amount of liquid detergent to the inside diameter of rotating half of seal.
6. Slide the rotating seal member, polished face last, over impeller sleeve until the rubber drive ring contacts the shoulder. **Note:** *Be sure not to nick or scratch the polished seal face. The seal will leak if the face is damaged.*
7. Screw the impeller onto the shaft (clockwise); this will automatically lock the seal in the seal plate. **Note:** *On models with an impeller screw: Install the impeller gasket and lock screw (left-hand thread - turn **counterclockwise**). Torque lock screw to 50-55 inch-lbs. (57.6-63 kg/cm).*
8. Mount the diffuser on the seal plate. Tighten the screws to 10-14 inch-lbs. (11.2-16.1 kg/cm) torque.
9. Assemble the motor and seal plate to the volute. Be sure the clamp is properly seated. **Note:** *Clamp knob can be located in any position around volute; if it is moved after assembly, tighten knob while tapping around clamp to assist sealing. Do not move clamp while pump is full of water.*

**⚠ WARNING** - Hazardous pressure. Release all pressure from pump and piping system before working on pump or attempting to adjust or remove clamp. Clamp may blow off of pump if adjusted under pressure.

10. Reconnect the RS-485 communication cable to the pump.
11. Fill the pump with water.
12. Reinstall the pump lid and the plastic clamp. See “Pump Strainer Basket” on page 23 for details.
13. Prime the pump. See “Priming the pump for the first time or after servicing,” on page 9 for details.

## Illustrated Parts List

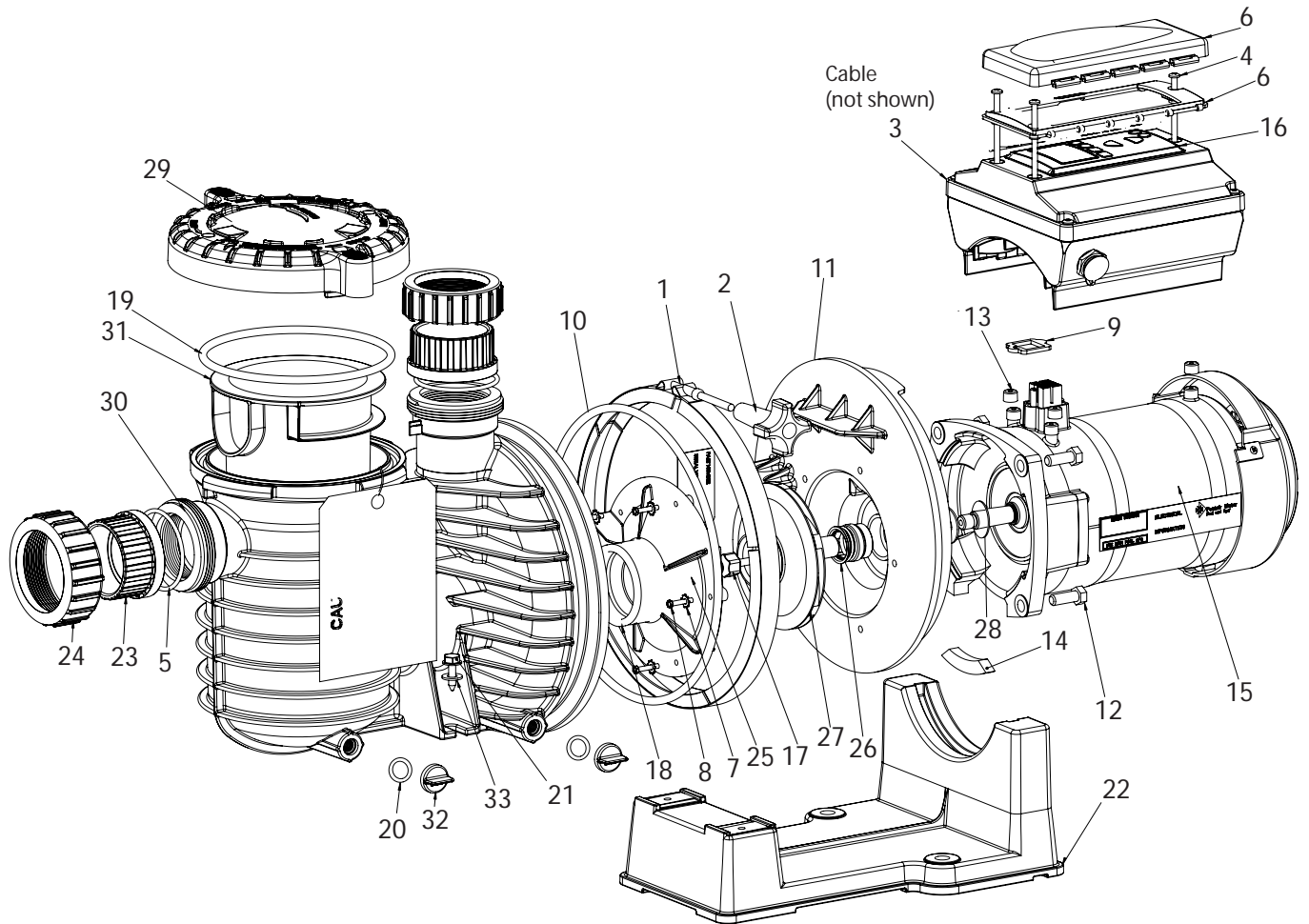

Item No.	Qty.	Part Number	Description	Item No.	Qty.	Part Number	Description
1	1	c19-37a	V-CLAMP	17	1	37337-6080	IMPELLER SCREW
2	1	wc36-22	CLAMP, KNOB	18	1	U9-374	O_RING
3	1	350122	CBL 50FT 2 COND (NOT SHOWN)	19	1	35505-1440	O-RING 6.90 O.D. 6.35 I.D.
4	3	350107	10-24 X 3 1/4" PH MS 18-8 SS	20	2	U9-359	O-RING DRAIN PLUG
5	2	U9-362	O-RING #2-231	21	2	u30-918	SCR 5/16-14 X 1 IN LG HI-LO HEX
6	1	357290	CVR CNTR ASSY, BLK	22	1	C4-78P	BASE
7	5	u43-21ss	#8 EXT TOOTH WASHER	23	2	U11-196P	2" NPT ADAPTER
8	5	u30-922ss	SCREW DIFFUSER	24	2	U11-200PS	UNION COLLAR
9	1	350108	GASKET INTELLIFLO DRIVE	25	1	c1-271P	DIFFUSER
10	1	u9-228a	O-RING	26	2	37400-0028	SHAFT SEAL, VITON
11	1	c103-194P	SEAL PLATE	27	1	C105-238PLA	IMPELLER ASSEMBLY
12	4	U30-99SS	SCR CAP 3/8-16 X 1" Soc Head	28	1	17351-0009	SLINGER PUMP SHAFT 1/16 IN
13	3	350142	CAP SPACER	29	1	17307-0111S	TRAP COVER ASSEMBLY *
14	1	C35-11	MOTOR PAD	30	1	17307-0110S	TANK BODY ASSEMBLY **
15	4	357294	MTR 3.2KW PMSM VFD	31	2	C8-58P	TRAP BASKET
16	1	357289	DRIVE 4SPD INTELLIFLO BLK	32	2	U78-920P	DRAIN PLUG
				33	2	u43-41SS	WASHER 5/16 TYPE B NARROW

### Note

(\*) Includes TRAP COVER, TRAP RING AND COVER O-RING

(\*\*) Includes TRAP BODY, BASKET, DRAIN PLUGS AND TRAP COVER ASSEMBLY

## IntelliPro Pump Dimensions

### IntelliPro Flow and Power vs Flow Pump Curve

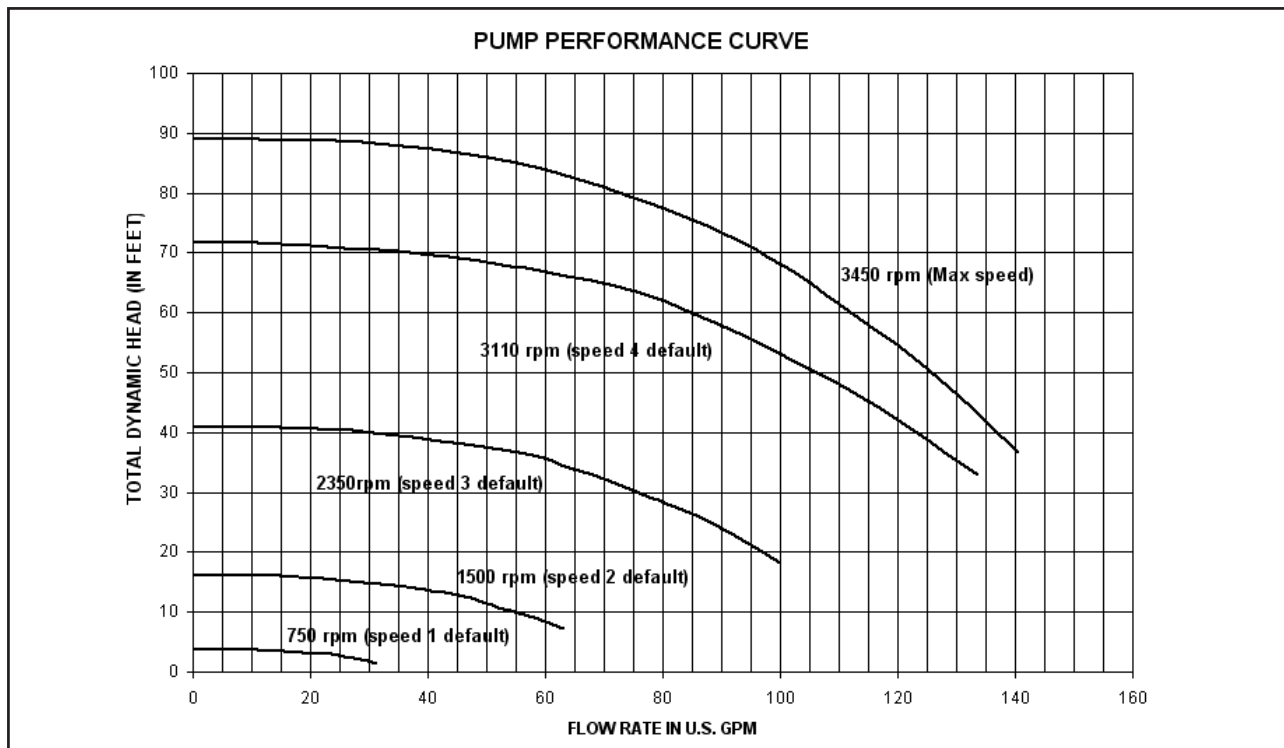

## IntelliPro Electrical Specifications

**Circuit Protection:** Two-pole 20 AMP device at the Electrical Panel.

Input: 230 VAC, 50/60 Hz, 3200 Watts

# Section 6

## Troubleshooting

**⚠ CAUTION:** Before installing this product, read and follow all warning notices and instructions on page ii.

### Warning and Alarm conditions

The IntelliPro alarms and warnings are indicated by flashing LEDs on the control panel. For example, if a “Drive Temperature” warning occurs, the LED will blink two times, then Off, then blink two times. This sequence is repeated until the condition is cleared.

- **Warning condition:** If a warning condition occurs the pump will be continue to run but at a reduced speed. The Green LED executes a sequence of blinks to indicate which alarm or warning has occurred.
- **Alarm condition:** If an alarm condition occurs the pump will drive stop running. The red LED flashes continuously to indicate the presence of an alarm. The alarm LEDs will reset when the condition clears.

### Alarm and warning LED sequence

Number of time the LED will blink	Alarm	Description	Action
2	Drive Temperature Warning	Excessive drive temperature	<ol style="list-style-type: none"> <li>1. Ensure the motor fan has adequate area for ventilation.</li> <li>2. Stop motor and allow to cool.</li> <li>3. Run motor at a higher speed to improve cooling air flow.</li> </ol>
5	Unknown alarm	Electron failure	<ol style="list-style-type: none"> <li>1. Cycle power to reset pump.</li> <li>2. Replace drive.</li> </ol>
6	Drive Temperature Alarm	Excessive drive temperature	<ol style="list-style-type: none"> <li>1. Ensure the motor fan has adequate area for ventilation.</li> <li>2. Run motor at a higher speed to improve cooling air flow.</li> </ol>
7	Power Out Alarm	Supply voltage low	Ensure proper supply voltage.
8	Over current Alarm	Excessive drive current	<ol style="list-style-type: none"> <li>1. Examine fluid/mechanical system for source of overload.</li> <li>2. De-energize motor and determine if motor spins freely.</li> <li>3. Replace drive.</li> </ol>
9	Over voltage Alarm	Excessive voltage on drive buss	<ol style="list-style-type: none"> <li>1. Rapid switching between speeds can cause excessive voltages on the drive's DC buss.</li> <li>2. Ensure proper supply voltage.</li> </ol>

## General IntelliPro Troubleshooting Problems

Use the following general troubleshooting information to resolve possible problems with your IntelliPro pump.

**Note:** Switch the main power off to the pump before attempting service or repair.

Problem	Possible Cause	Corrective Action
Pump failure. Refer to Alarm LED sequence on page 27.	<p>Pump will not prime - Air leak in suction.</p> <p>Pump will not prime - Not enough water.</p> <p>Pump strainer clogged.</p> <p>Pump strainer gasket defective.</p>	<p>Check suction piping and valve glands on any suction gate valves.</p> <p>Secure lid on pump strainer pot and make sure lid gasket is in place.</p> <p>Check water level to make sure skimmer is not drawing air.</p> <p>Ensure that the suction lines, pump, strainer, and pump volute are full of water.</p> <p>Clean pump strainer pot.</p> <p>Replace gasket.</p>
Reduced capacity and / or head. Refer to Alarm LED sequence on page 27.	<p>Air pocket or leaks in suction line.</p> <p>Clogged impeller.</p> <p>Pump strainer clogged.</p>	<p>Check suction piping and valve glands on any suction gate valves.</p> <p>Turn off electrical power to the pump.</p> <p>Remove the (6) bolts that hold the volute to the seal plate.</p> <p>Slide the motor and seal plate away from the volute.</p> <p>Clean debris from impeller. If debris cannot be removed, complete the following steps.</p> <ol style="list-style-type: none"> <li>1. Remove diffuser and o-ring.</li> <li>2. Remove left hand thread anti-spin bolt and o-ring.</li> <li>3. Remove, clean and reinstall impeller.</li> <li>4. Reinstall anti-spin bolt and o-ring.</li> </ol> <p>Reinstall diffuser, and o-ring.</p> <p>Reinstall motor and seal plate into volute.</p> <p>Reinstall (6) bolts around seal plate and volute and tighten securely.</p> <p>Clean suction trap.</p>

## Problems and Corrective Action (Continued)

Problem	Possible Cause	Corrective Action
Circuit breaker trips repeatedly. Refer to Alarm LED sequence on page 27.	Excessive motor current.  GFCI fault.	Breaker must be of adequate capacity. For GFCI breaker, test according to GFCI manufacturer's instructions. Be sure no other lights and appliances are on circuit. Voltage too high or too low.
Electrical problem. Refer to Alarm LED sequence on page 27.	Pump may be too hot.	Check line voltage; if less than 90% or more than 110% of rated voltage consult a licensed electrician. Increase ventilation. Reduce ambient temperature. Tighten any loose wiring connections. Motor internal terminal overload protector is open. Motor runs too hot. Turn power to motor off. Check for proper voltage. Check for proper impeller or impeller rubbing.
Mechanical Troubles and Noise.	The pump motor is running but with loud noise.          Cavitation.	If suction and discharge piping are not adequately supported, pump assembly will be strained. Do not mount pump on a wooden platform! Securely mount on concrete platform for quietest performance. Foreign matter (gravel, metal, etc.) in pump impeller. Disassemble pump, clean impeller, follow pump service instructions for reassembly.  Improve suction conditions. Increase pipe size. Decrease number of fittings. Increase discharge pressure.

**STA-RITE®**

